



厦门市鑫荣飞汽车部件制造有限公司

厦门市鑫荣飞工贸有限公司

经营理念

operation principle

诚信

创新

协力

共享

Sincerity

Innovating

Cooperation

Share



企业性质 Company character	民营企业 Private enterprise
法人 Legal person	骆文芳 Amy Luo
投产时间 Established in	Since 1997
注册资金 Registered Capital	RMB10, 000, 000
土地面积 Land Area	12000m²
厂房面积 Plant Area	18000m²
员工人数 Qty of Employee	188

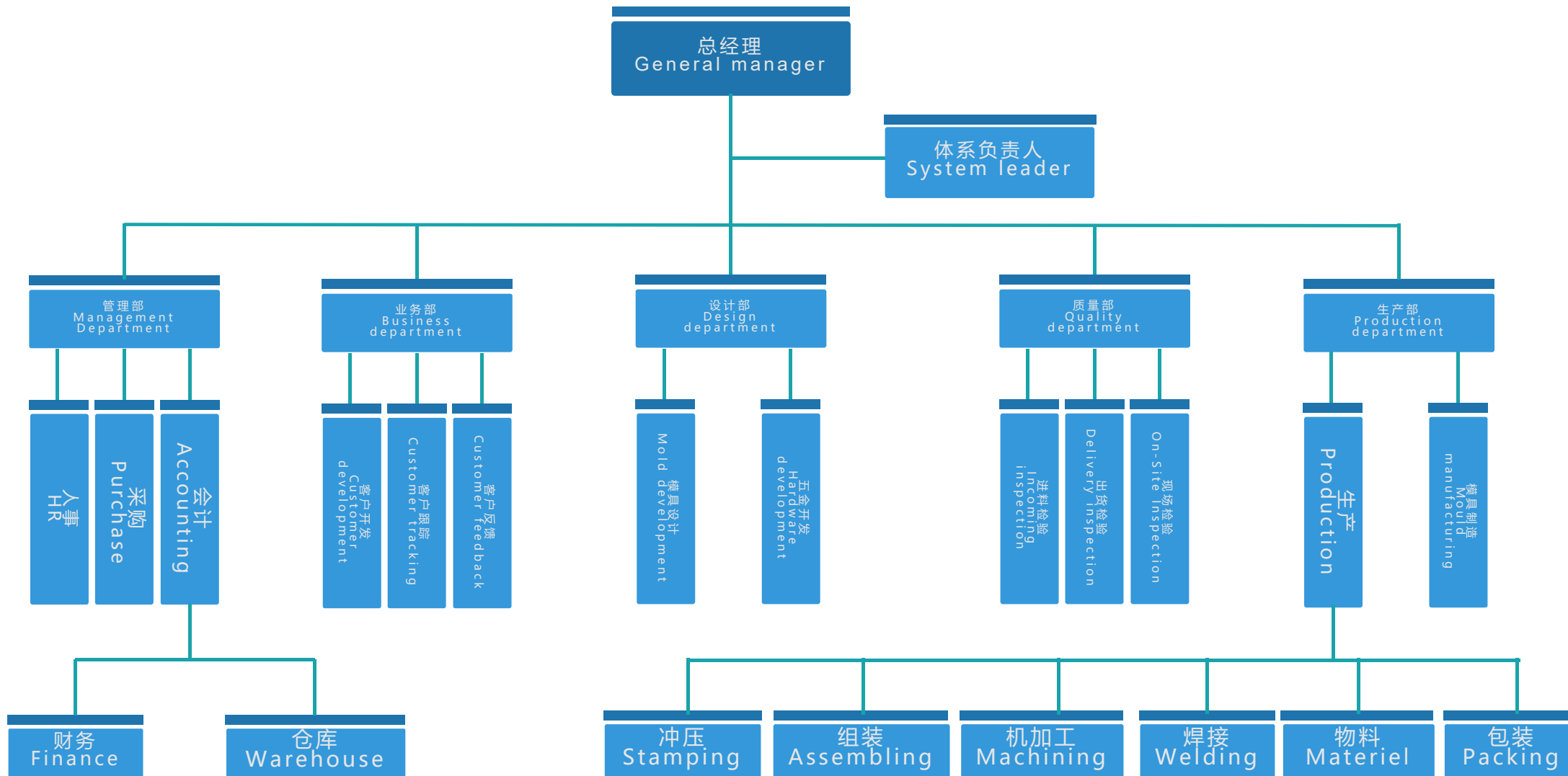

中国 CHINA



格拉默

仕驰汽车配套部件(上海)有限公司

浙江天成自控股份有限公司

加拿大木桥

柳州市汽车座椅有限公司

廊坊全兴希尔思交通器材有限公司

无锡威孚智行座椅有限公司

扬州高升机械有限公司

高邮市怡和车辆附件有限公司

赛夫华兰德 (扬州) 车辆部件有限公司

捷太格特转向系统 (厦门) 有限公司

厦门民兴工业有限公司

厦门连科工业有限公司

全球 World

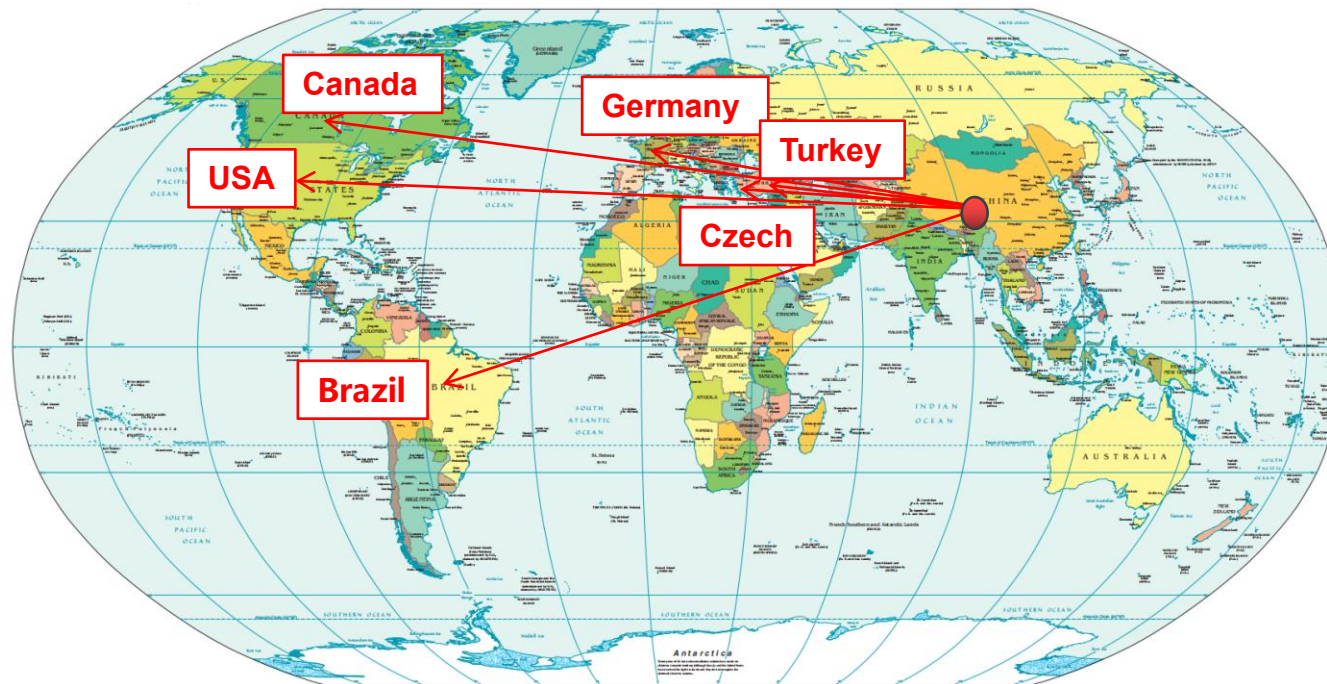



连续模具 / 多工位模具 / 高强度钢板
Continuous die / multi position die / high strength steel plate

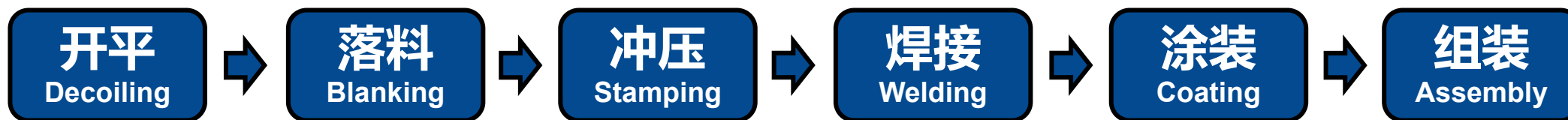

Thickness < 3.2mm
Width < 500mm

Thickness < 12mm
Width < 1000mm

Max 1200T
Min 25T

Robot welding
Projection welding

Cathodic
electrophoresis



座椅滑轨
Seat slider

管件成型件
Tube forming parts

汽车零部件
Auto parts

机加工零部件
Machining parts

LED灯散热杯
LED light Cooling cap

轮椅车部件
Wheelchair parts

铝挤型制品
Aluminum products

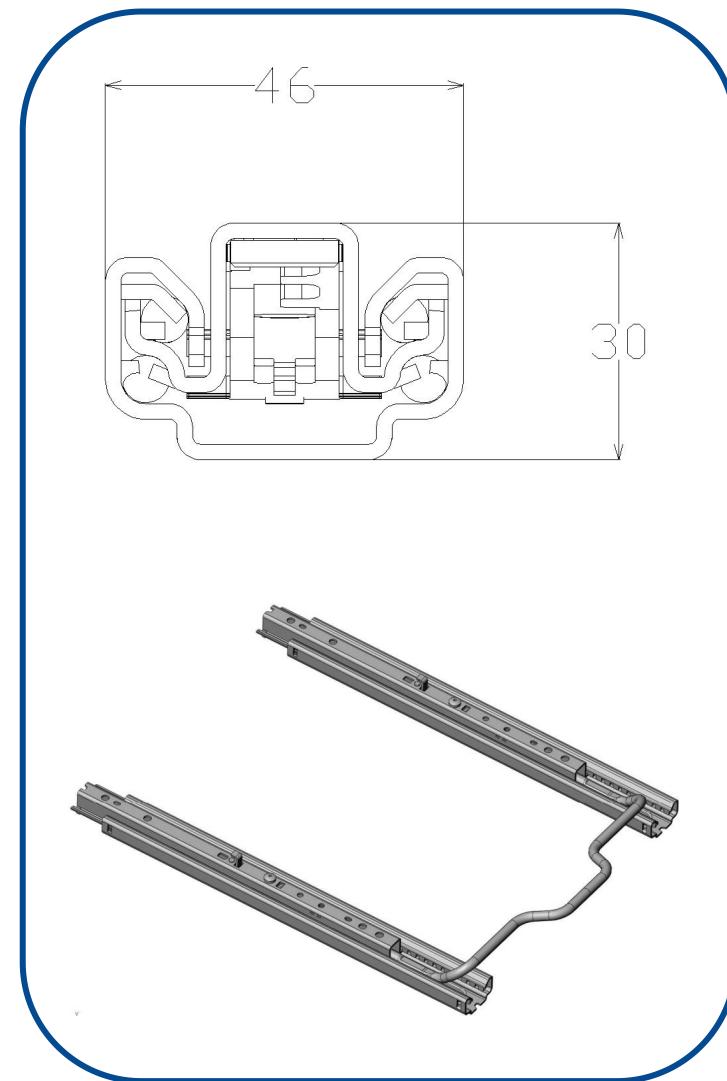

座椅滑轨
Seat slider

管件成型件
Tube forming parts

汽车零部件
Auto parts

机加工零部件
Machining parts

LED灯散热杯
LED light Cooling cap

轮椅车部件
Wheelchair parts

铝挤型制品
Aluminum products

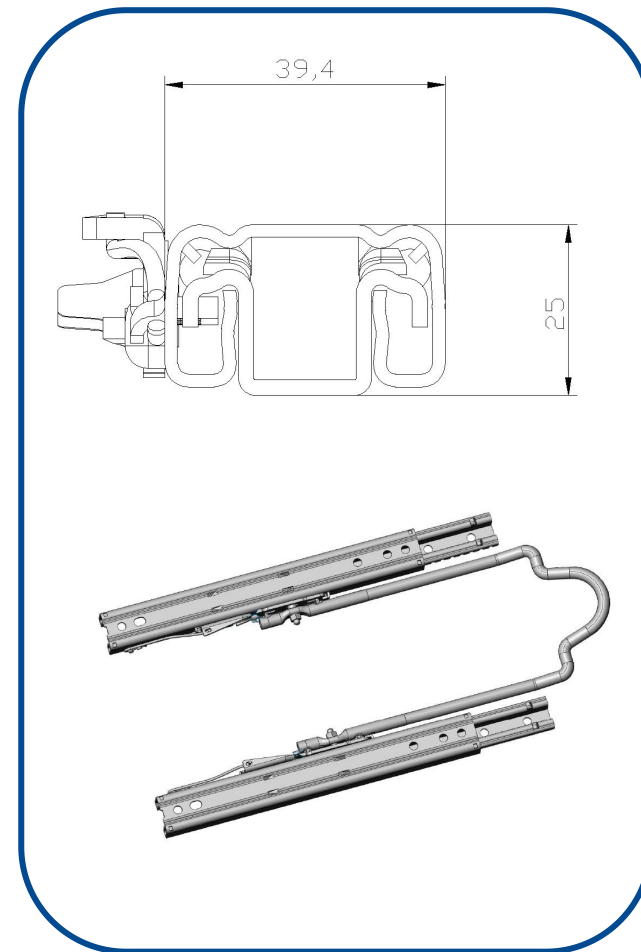

座椅滑轨
Seat slider

管件成型件
Tube forming parts

汽车零部件
Auto parts

机加工零部件
Machining parts

LED灯散热杯
LED light Cooling cap

轮椅车部件
Wheelchair parts

铝挤型制品
Aluminum products



座椅滑轨
Seat slider

管件成型件
Tube forming parts

汽车零部件
Auto parts

机加工零部件
Machining parts

LED灯散热杯
LED light Cooling cap

轮椅车部件
Wheelchair parts

铝挤型制品
Aluminum products

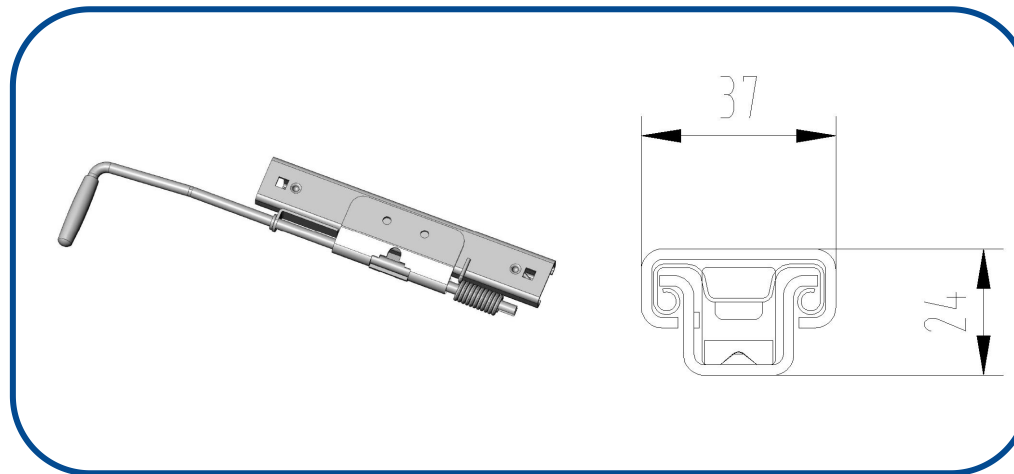

座椅滑轨
Seat slider

管件成型件
Tube forming parts

汽车零部件
Auto parts

机加工零部件
Machining parts

LED灯散热杯
LED light Cooling cap

轮椅车部件
Wheelchair parts

铝挤型制品
Aluminum products

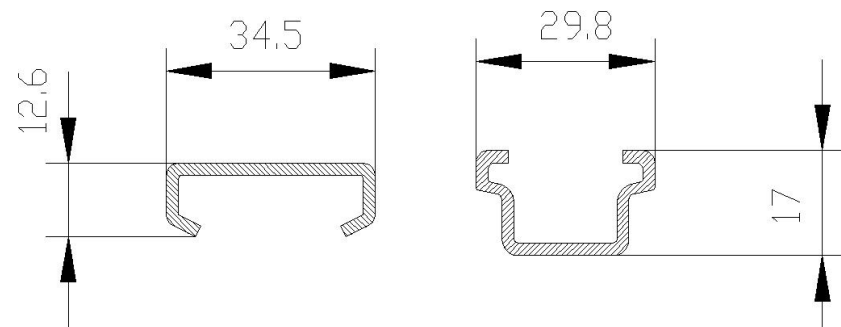

座椅滑轨
Seat slider

管件成型件
Tube forming parts

汽车零部件
Auto parts

机加工零部件
Machining parts

LED灯散热杯
LED light Cooling cap

轮椅车部件
Wheelchair parts

铝挤型制品
Aluminum products

Single release lever



Dual release lever

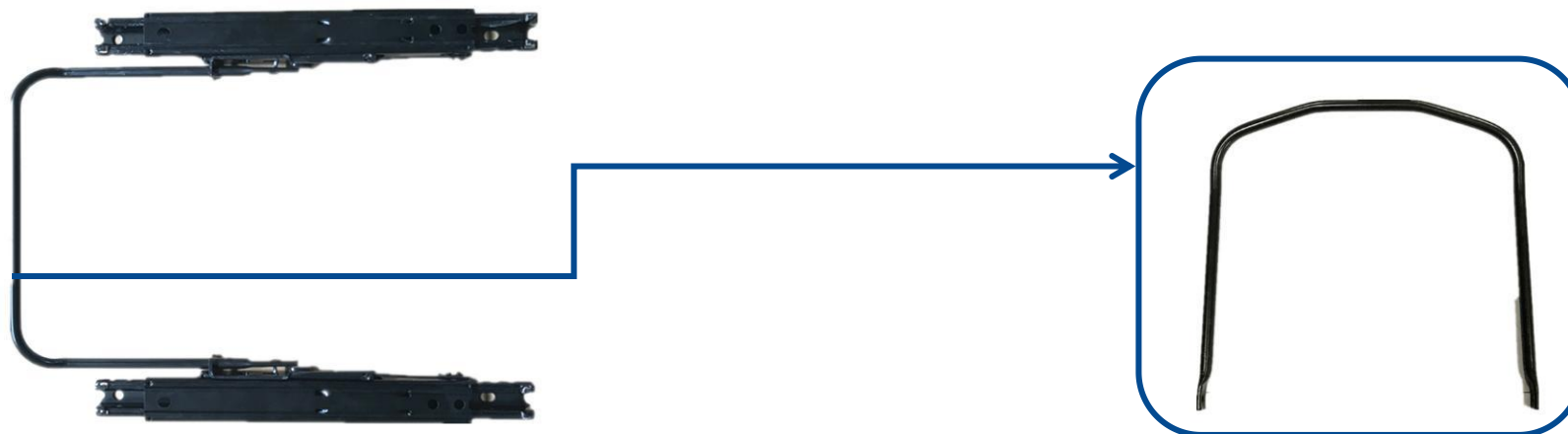

座椅滑轨
Seat slider

管件成型件
Tube forming parts

汽车零部件
Auto parts

机加工零部件
Machining parts

LED灯散热杯
LED light Cooling cap

轮椅车部件
Wheelchair parts

铝挤型制品
Aluminum products



座椅滑轨
Seat slider

管件成型件
Tube forming parts

汽车零部件
Auto parts

机加工零部件
Machining parts

LED灯散热杯
LED light Cooling cap

轮椅车部件
Wheelchair parts

铝挤型制品
Aluminum products



悬挂侧板
Hanging side plate



悬挂压板
Hanging pressure plate

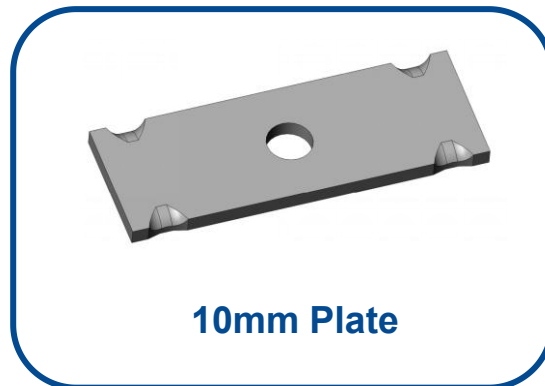

支腿部件
Outrigger parts



座椅滑轨
Seat slider

管件成型件
Tube forming parts

汽车零部件
Auto parts

机加工零部件
Machining parts

LED灯散热杯
LED light Cooling cap

轮椅车部件
Wheelchair parts

铝挤型制品
Aluminum products

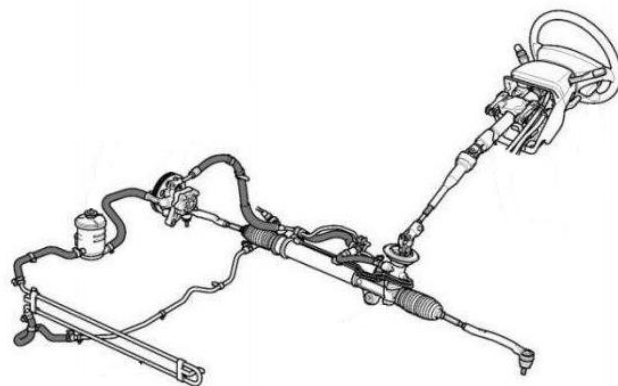

转向系统部件
Steering system components



座椅滑轨
Seat slider

管件成型件
Tube forming parts

汽车零部件
Auto parts

机加工零部件
Machining parts

LED灯散热杯
LED light Cooling cap

轮椅车部件
Wheelchair parts

铝挤型制品
Aluminum products



座椅滑轨
Seat slider

管件成型件
Tube forming parts

汽车零部件
Auto parts

机加工零部件
Machining parts

LED灯散热杯
LED light Cooling cap

轮椅车部件
Wheelchair parts

铝挤型制品
Aluminum products



座椅滑轨
Seat slider



管件成型件
Tube forming parts

汽车零部件
Auto parts

机加工零部件
Machining parts

LED灯散热杯
LED light Cooling cap



轮椅车部件
Wheelchair parts

铝挤型制品
Aluminum products



散热杯
Cooling cup

散热筒灯
Cooling downlight

座椅滑轨
Seat slider

管件成型件
Tube forming parts

汽车零部件
Auto parts

机加工零部件
Machining parts

LED灯散热杯
LED light Cooling cap

轮椅车部件
Wheelchair parts

铝挤型制品
Aluminum products

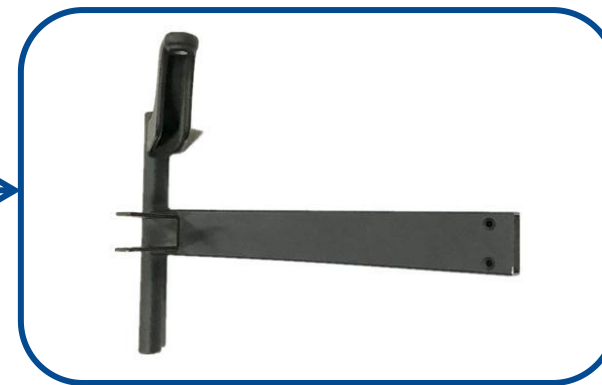

座椅滑轨
Seat slider



管件成型件
Tube forming parts

汽车零部件
Auto parts

机加工零部件
Machining parts

LED灯散热杯
LED light Cooling cap

轮椅车部件
Wheelchair parts

铝挤型制品
Aluminum products



材料来源

Source of materials:

宝钢

Baosteel



Continuous die production line 连续模冲压线

Three dimensional slider rail forming line 三次元滑轨成型线

Multi station slider forming line 多工位油压成型线

Multi station stretching machining line 多工位拉伸加工线

Stamping production line 工程模冲压线

Slider rail assembly line 滑轨组装线

Pipe fitting processing line 弯管加工线

Welding line 焊接总成线

CNC lathe processing line 数控车床加工线

Center line of drilling and tapping 钻攻中心

Aluminum extrusion line 铝挤型线

Mould processing equipment 模具加工设备



连续模冲压线

Continuous die production line



Continuous die production line 连续模冲压线

Three dimensional slider rail forming line 三次元滑轨成型线

Multi station slider forming line 多工位油压成型线

Multi station stretching machining line 多工位拉伸加工线

Stamping production line 工程模冲压线

Slider rail assembly line 滑轨组装线

Pipe fitting processing line 弯管加工线

Welding line 焊接总成线

CNC lathe processing line 数控车床加工线

Center line of drilling and tapping 钻攻中心

Aluminum extrusion line 铝挤型线

Mould processing equipment 模具加工设备



三次元滑轨成型线

Three dimensional manipulator automatic line

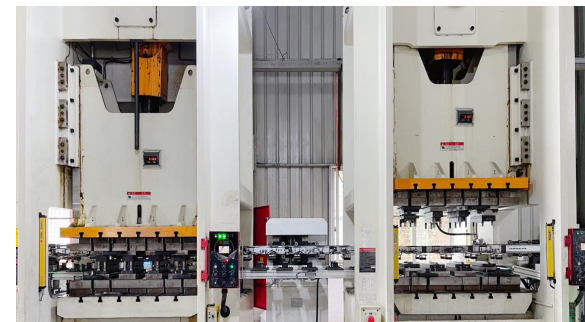

二次元机械手自动线

Two dimensional manipulator automatic line

Continuous die production line 连续模冲压线

Three dimensional slider rail forming line 三次元滑轨成型线

Multi station slider forming line 多工位油压成型线

Multi station stretching machining line 多工位拉伸加工线

Stamping production line 工程模冲压线

Slider rail assembly line 滑轨组装线

Pipe fitting processing line 弯管加工线

Welding line 焊接总成线

CNC lathe processing line 数控车床加工线

Center line of drilling and tapping 钻攻中心

Aluminum extrusion line 铝挤型线

Mould processing equipment 模具加工设备

油压机 Hydraulic Press



Continuous die production line 连续模冲压线

Three dimensional slider rail forming line 三次元滑轨成型线

Multi station slider forming line 多工位油压成型线

Multi station stretching machining line 多工位拉伸加工线

Stamping production line 工程模连线冲压线

Slider rail assembly line 滑轨组装线

Pipe fitting processing line 弯管加工线

Welding line 焊接总成线

CNC lathe processing line 数控车床加工线

Center line of drilling and tapping 钻攻中心

Aluminum extrusion line 铝挤型线

Mould processing equipment 模具加工设备

工程模连线冲压线

Stamping production line

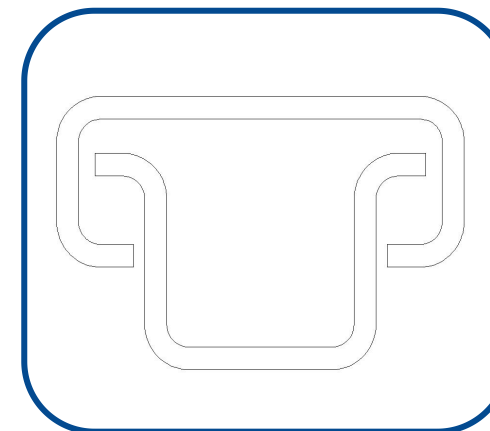

Continuous die production line 连续模冲压线

Three dimensional slider rail forming line 三次元滑轨成型线

Multi station slider forming line 多工位油压成型线

Multi station stretching machining line 多工位拉伸加工线

Stamping production line 工程模冲压线

Slider rail assembly line 滑轨组装线

Pipe fitting processing line 弯管加工线

Welding line 焊接总成线

CNC lathe processing line 数控车床加工线

Center line of drilling and tapping 钻攻中心

Aluminum extrusion line 铝挤型线

Mould processing equipment 模具加工设备

全自动滑轨装配线

Automatic slide rail assembly line

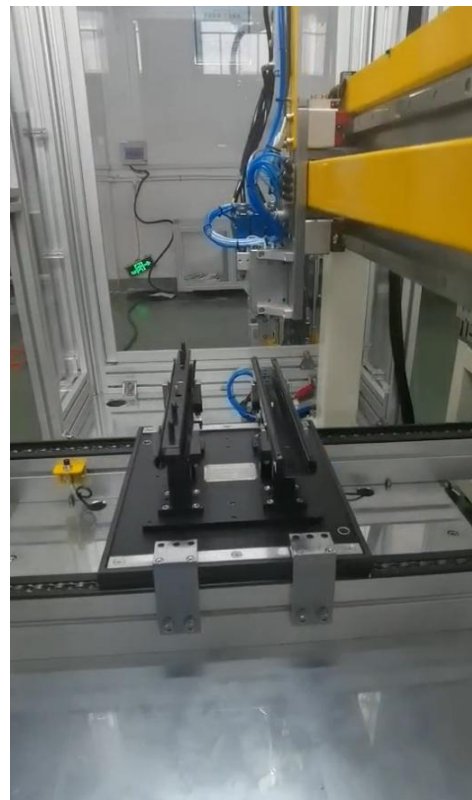

Continuous die production line 连续模冲压线

Three dimensional slider rail forming line 三次元滑轨成型线

Multi station slider forming line 多工位油压成型线

Multi station stretching machining line 多工位拉伸加工线

Stamping production line 工程模冲压线

Slider rail assembly line 滑轨组装线

Pipe fitting processing line 弯管加工线

Welding line 焊接总成线

CNC lathe processing line 数控车床加工线

Center line of drilling and tapping 钻攻中心

Aluminum extrusion line 铝挤型线

Mould processing equipment 模具加工设备

半自动滑轨装配线

Semi automatic slide rail assembly line



Continuous die production line
连续模冲压线

Three dimensional slider rail forming line
三次元滑轨成型线

Multi station slider forming line
多工位油压成型线

Multi station stretching machining line
多工位拉伸加工线

Stamping production line
工程模冲压线

Slider rail assembly line
滑轨组装线

Pipe fitting processing line
弯管加工线

Welding line
焊接总成线

CNC lathe processing line
数控车床加工线

Center line of drilling and tapping
钻攻中心

Aluminum extrusion line
铝挤型线

Mould processing equipment
模具加工设备

下料机

Blanking machine

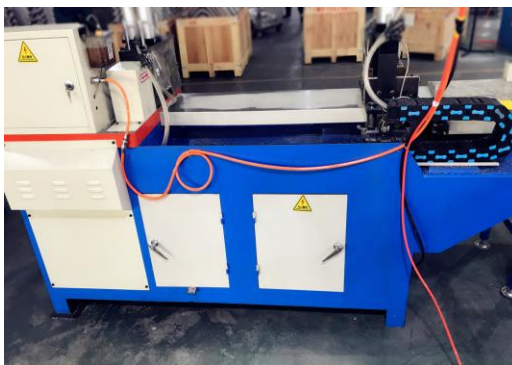

倒角机

Chamfering machine



弯管机

Pipe bending machine

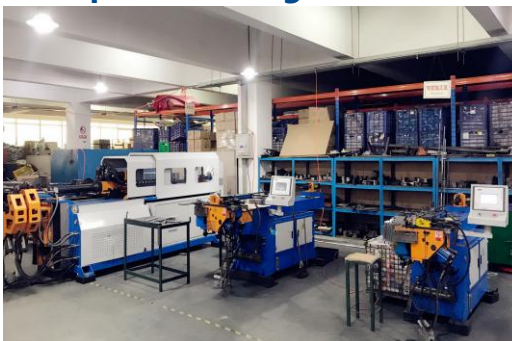

抛光机

Polishing machine



Continuous die production line
连续模冲压线

Three dimensional slider rail forming line
三次元滑轨成型线

Multi station slider forming line
多工位油压成型线

Multi station stretching machining line
多工位拉伸加工线

Stamping production line
工程模冲压线

Slider rail assembly line
滑轨组装线

Pipe fitting processing line
弯管加工线

Welding line
焊接总成线

CNC lathe processing line
数控车床加工线

Center line of drilling and tapping
钻攻中心

Aluminum extrusion line
铝挤型线

Mould processing equipment
模具加工设备

焊接机器人 Welding robot



凸焊机 Projection welding machine

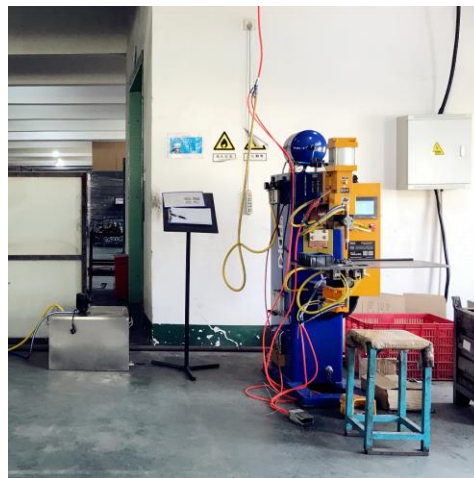

铝焊机 Aluminum welding machine



Continuous die production line
连续模冲压线

Three dimensional slider rail forming line
三次元滑轨成型线

Multi station slider forming line
多工位油压成型线

Multi station stretching machining line
多工位拉伸加工线

Stamping production line
工程模冲压线

Slider rail assembly line
滑轨组装线

Pipe fitting processing line
弯管加工线

Welding line
焊接总成线

CNC lathe processing line
数控车床加工线

Center line of drilling and tapping
钻攻中心

Aluminum extrusion line
铝挤型线

Mould processing equipment
模具加工设备

数控车床 CNC Lathe



Continuous die production line 连续模冲压线

Three dimensional slider rail forming line 三次元滑轨成型线

Multi station slider forming line 多工位油压成型线

Multi station stretching machining line 多工位拉伸加工线

Stamping production line 工程模冲压线

Slider rail assembly line 滑轨组装线

Pipe fitting processing line 弯管加工线

Welding line 焊接总成线

CNC lathe processing line 数控车床加工线

Center line of drilling and tapping 钻攻中心

Aluminum extrusion line 铝挤型线

Mould processing equipment 模具加工设备

钻攻中心 Tapping center



Continuous die production line
连续模冲压线

Three dimensional slider rail forming line
三次元滑轨成型线

Multi station slider forming line
多工位油压成型线

Multi station stretching machining line
多工位拉伸加工线

Stamping production line
工程模冲压线

Slider rail assembly line
滑轨组装线

Pipe fitting processing line
弯管加工线

Welding line
焊接总成线

CNC lathe processing line
数控车床加工线

Center line of drilling and tapping
钻攻中心

Aluminum extrusion line
铝挤型线

Mould processing equipment
模具加工设备



Continuous die production line
连续模冲压线

Three dimensional slider rail forming line
三次元滑轨成型线

Multi station slider forming line
多工位油压成型线

Multi station stretching machining line
多工位拉伸加工线

Stamping production line
工程模冲压线

Slider rail assembly line
滑轨组装线

Pipe fitting processing line
弯管加工线

Welding line
焊接总成线

CNC lathe processing line
数控车床加工线

Center line of drilling and tapping
钻攻中心

Aluminum extrusion line
铝挤型线

Mould processing equipment
模具加工设备

CNC加工中心

CNC machining center



线切割机

Wire cutting machine



模具组装车间

Mold assembly workshop



2007年通过ISO9001认证 2007 Passed ISO9001 Quality Management System Certification



2020年1月通过IATF16949认证 2020 January Passed IATF16949 Quality Management System Certification



强度拉力机 5吨

Universal material testing machine 5T



强度拉力机 10吨

Universal material testing machine 10T



滑轨耐久测试机
Track durability tester



耐久测试机
Durability tester



全自动影像测量仪

Automatic image measuring instrument



三坐标测量仪

Three coordinate measuring instrument



熔深测量仪

Penetration measuring instrument



滑轨间隙测量仪

Slider rail gap detector



盐雾试验机

Salt spray tester



洛氏硬度计

Rockwell hardness tester



光谱仪

Spectrometer



Contact us:



骆文芳 Amy Luo

柴建飞 Jianfei Chai



总经理 General manager.

总经理 General manager.



+86 13860119863

+86 13559238658



Luowenfang@sunrfly.com

Chaijianfei@sunrfly.com



公司总机: 0592-5788907 5788909 5788797

直线电话: 0592-5788199



传真号码: 0592-5788197



福建省厦门市海沧区新阳街道后祥西路一号 (2#厂房)

(No.2 Buliding) No.1 Houxiang West Road,Xinyang Street, Haicang District, Xiamen,Fujian,CHINA

We keep working on improvements!

Thank you for your attention!

