

公司简介

Company profile

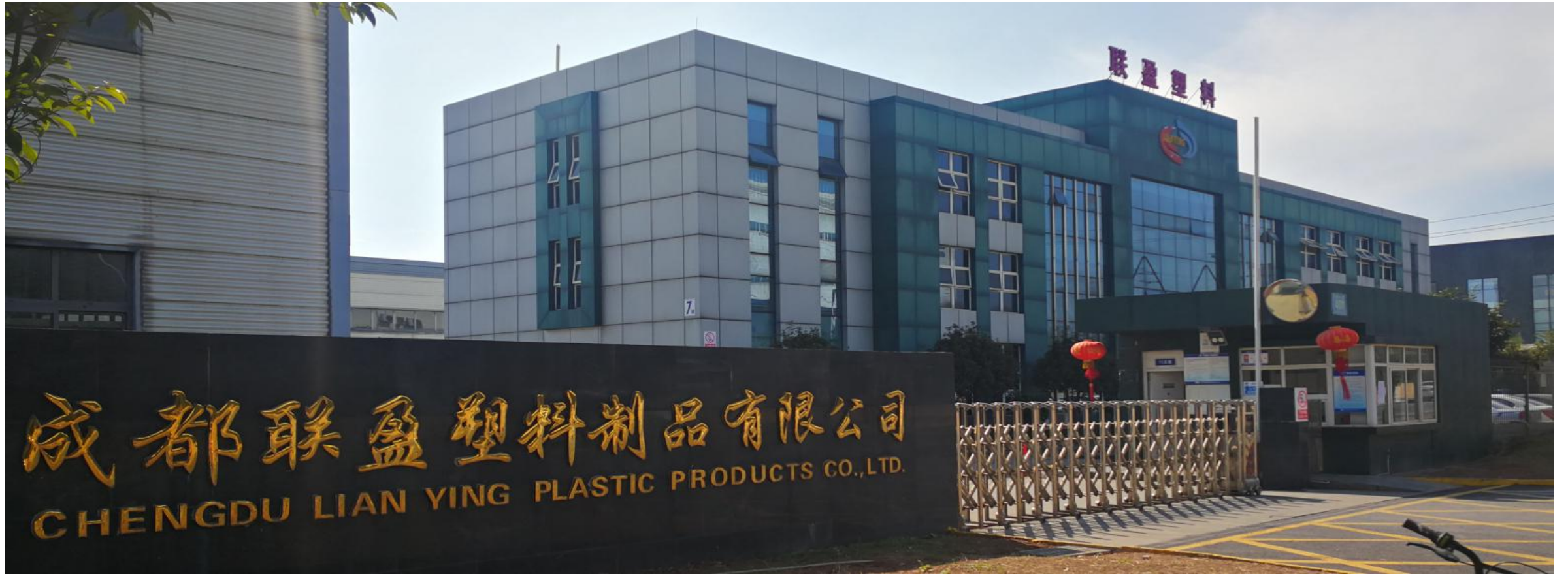

成都联盈塑料制品有限公司
Chengdu LianYing Plastics Products CO.,LTD.

1

公司概况

Company profile



2

管理能力

Management capacity



3

项目开发

Project development



4

生产能力

Production capacity





注册日期：2010年1月22日 注册资金：600万

自建厂房，占地面积：2万平方米，建筑面积：1万2千平方米。

集产品研发、制造、销售为一体的专业注塑企业；业务覆盖汽车内外饰、物流包装、家电、民用塑料制品等领域。员工：96名，其中主要管理人员：8人，技术人员：10人，年生产能力1千万件。

Registration date: January 22, 2010 registered capital :6 million

Self-built factory building, covering an area of 20,000 square meters, building area of 12,000 square meters, is a professional injection molding enterprise integrating product r&d, manufacturing and sales. Our business covers the fields of automobile interior and exterior decoration, logistics, packaging, household appliances, civil plastic products, etc., with 96 employees, including 8 main management personnel and 10 technical personnel. Our annual production capacity is 10 million pieces.

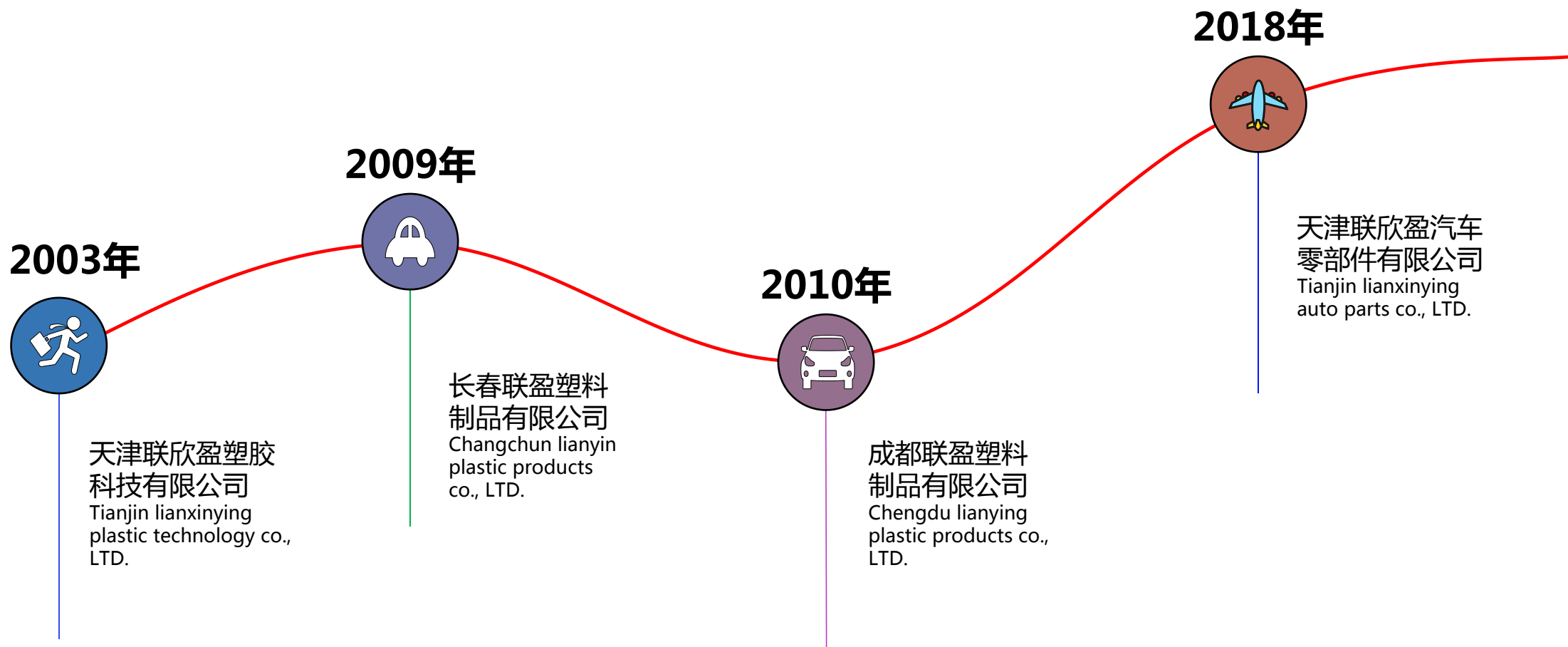

2013

IATF16949质量体系认证

IATF16949 quality system certification



质量管理体系认证证书

成都联盈塑料制品有限公司

认证范围：汽车零部件制造

IATF16949:2016

颁发日期：2013年10月20日

有效期至：2016年10月19日

认证标准：IATF16949

CSCC注册号：20130717-3

北京九鼎国联认证有限公司

2014

优秀质量奖

Excellent quality award



荣誉证书

成都联盈塑料制品有限公司

荣获2014年度成都地区供应商

优秀质量奖

特发此证，以资鼓励。

二〇一四年十二月

2015

安全生产三级企业

Safe production level 3 enterprises



安全生产标准化

三级企业

成都联盈塑料制品有限公司

(工贸)

成都市应急管理局颁发

中华人民共和国应急管理部监制

二〇一五年七月十五日

2017

ISO14001环境体系认证

ISO14001 environmental system certification



CERTIFICATE OF REGISTRATION

认证证书

成都联盈塑料制品有限公司

认证范围：汽车零部件生产

GB/T24001-2016/ISO14001:2015

颁发日期：2017年10月20日

有效期至：2019年10月19日

认证标准：GB/T24001-2016/ISO14001:2015

北京九鼎国联认证有限公司

2018

SQ 认证

SQ certification

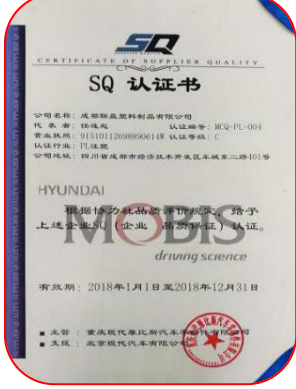

CERTIFICATE OF SUPERIOR QUALITY

SQ 认证证书

成都联盈塑料制品有限公司

认证范围：汽车零部件生产

颁发日期：2018年1月1日

有效期至：2018年12月31日

认证标准：SQ

北京九鼎国联认证有限公司

2020

ISO45001职业健康安全管理体系认证

ISO45001 Occupational Health and Safety Management System Certification



职业健康安全管理体系认证证书

成都联盈塑料制品有限公司

认证范围：汽车零部件生产

颁发日期：2020年1月1日

有效期至：2022年12月31日

认证标准：GB/T45001-2020 / ISO45001:2018

北京九鼎国联认证有限公司

2

管理能力
Management capacity



组织架构
Organizational
structure

核心成员
Core members

经营理念
Operation
principle

现场管理
Site
Management

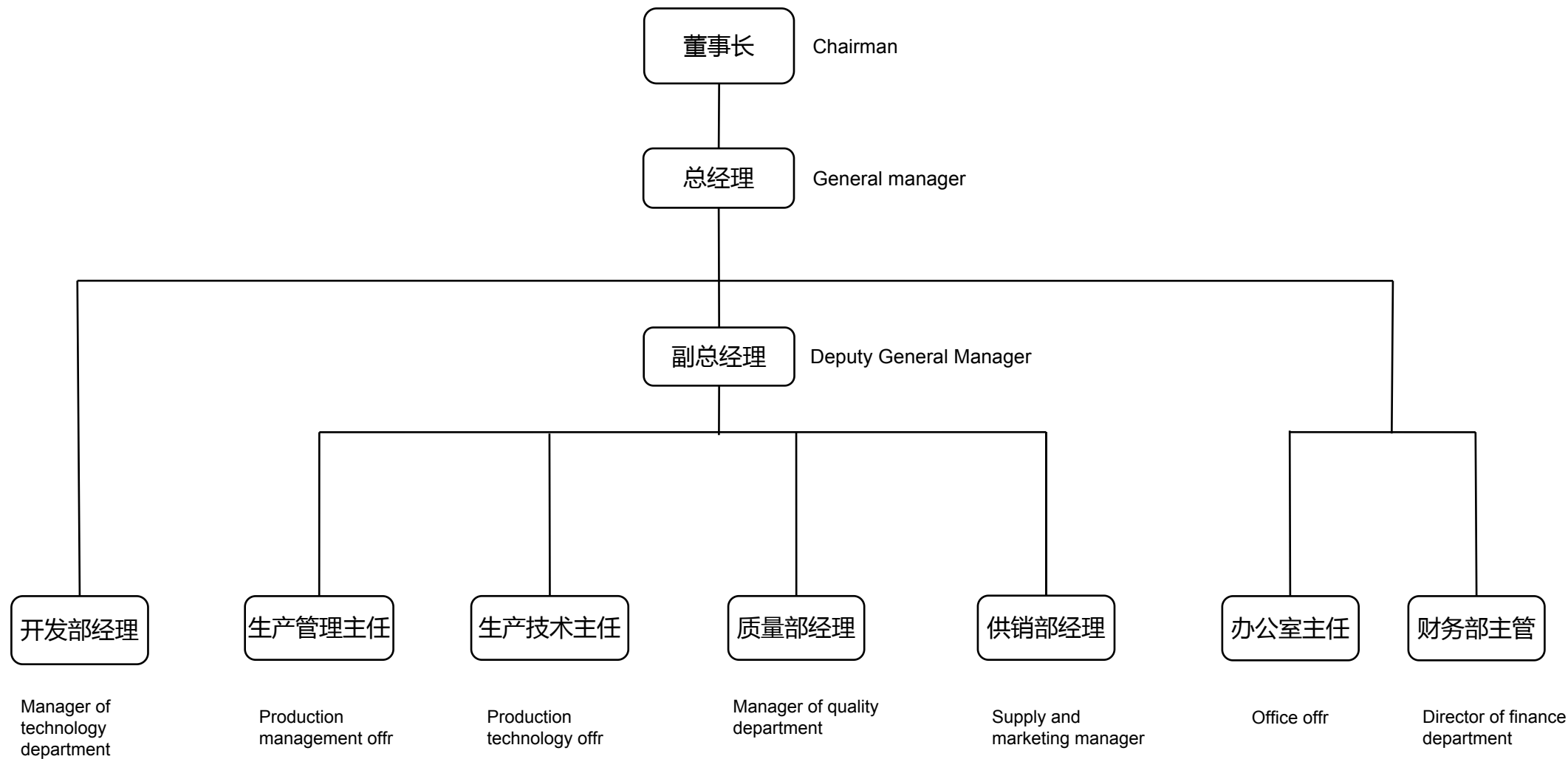



注塑区域
Injection molding area



模具区域
The mold area



检具区域
Submit the area



成品库房
The finished product warehouse



材料库房
Warehouse



实验室
lab

现场管理采用科学的管理制度和标准化工作流程。对人、机、料、法、环进行合理有效的计划、组织、协调、控制和检测，使其处于良好的结合状态，达到优质、高效、低耗、均衡、安全、文明生产的目的。

Adopt scientific management system and standardized workflow. We need to plan, organize, coordinate, control and test people, machines, materials, methods and rings in a reasonable and effective way, so that they can be in a good state of integration and achieve the goals of high-quality, efficient, low-consumption, balanced, safe and civilized production.

3

项目开发

Project
development



合作理念

The concept of
cooperation

开发历程

Development
history

客户分布

Customer
distribution

主要客户

Principal client

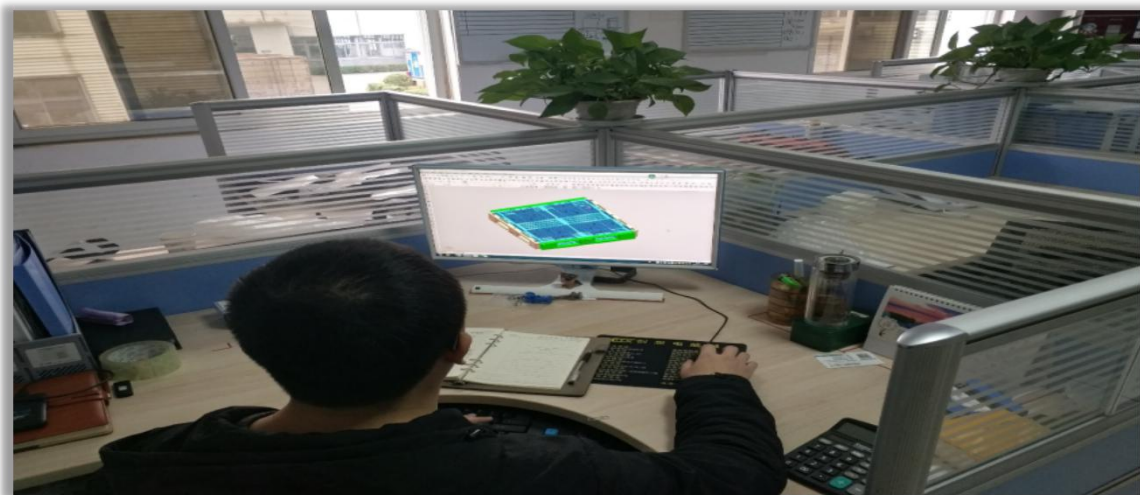

产品设计 Product Design

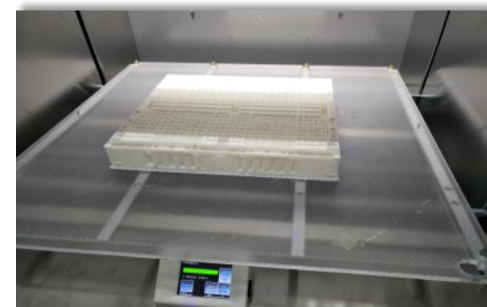
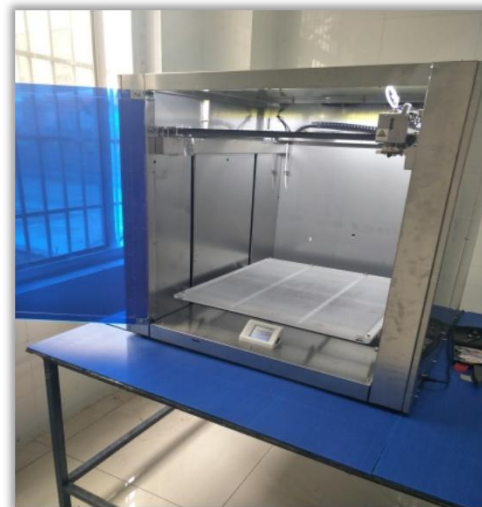

3D打印验证 3D printing validation



模具监造 Mould Supervision



注塑生产 Injection Production



客户主要分布：四川、
重庆、山东。
Customer
distribution: sichuan
chongqing shandong



4

生产能力

Production
capacity



设备状态
Device Status

设备参数
Equipment
parameter

重点设备
The key equipment

实验设备
Experimental
facilities

优势产品
Superior
product

代表产品
Representative
products



- 1、注塑机 (东华) 从90T-2850T一共19台，其中双色注塑机6台。
injection molding machine(Donghua) from 90 T-2850T a total of 19 units, of which two color injection molding machine 6 units.
- 2、挤出机一台。 one extruder.

序号	吨位	出厂年月	射台行程 (mm)	射胶行程 (mm)	顶针行程 (mm)	锁模行程 (mm)	射咀 (SR)、孔 径 (mm)	四柱间距 (mm)	模板最大间距 (mm)	最小模具尺寸 (mm)	容模量 (mm)	品牌
1	90	2011-7	255	161	85	320	SR10* \varnothing 3	360*360	680	250*250	150~360	东华注塑机
2	160	2011-7	320	207	130	446	SR10* \varnothing 3.3	460*460	906	320*320	150~460	东华注塑机
3	190	2018-9	360	232	140	490	SR10* \varnothing 3.5	510*510	1000	350*350	175~510	东华注塑机
3	190	2011-7	360	230	140	490	SR10* \varnothing 3.5	510*510	1000	350*350	175~510	东华注塑机
5	260	2011-7	400	253	160	525	SR15* \varnothing 4	580*580	1105	400*400	200~580	东华注塑机
6	320	2011-7	435	276	180	590	SR15* \varnothing 5	660*660	1540	460*460	540~950	东华注塑机
7	320 (双色机)	2011-7	435/255	276/161	180	590	SR15* \varnothing 5	660*660	1540	460*460	540~950	东华注塑机
8	450 (双色机)	2011-7	480/300	368/184	250	740	SR15* \varnothing 5	780*780	1560	540*540	300~820	东华注塑机
9	450 (双色机)	2013-12	480/300	368/184	250	740	SR15* \varnothing 5	780*780	1560	540*540	300~820	东华注塑机
10	660	2018-9	600	440	300	920	SR19* \varnothing 5	920*920	1830	645*645	350~920	东华注塑机
11	600	2011-7	600	412	300	910	SR19* \varnothing 5	900*900	1820	630*630	350~910	东华注塑机
12	800	2014-12	600	470	350	1025	SR19* \varnothing 6.5	1000*1000	2050	700*700	350~1025	东华注塑机
13	800 (双色机)	2014-12	600	470	350	1025	SR19* \varnothing 6.5	1000*1000	2050	700*700	350~1025	东华注塑机
14	800 (双色机)	2014-11	600	470	350	1025	SR19* \varnothing 6.5	1000*1000	2050	700*700	350~1025	东华注塑机
15	800 (双色机)	2018-9	600/360	470/232	350	1025	SR19* \varnothing 6.5	1000*1000	2350	700*700	350~1025	东华注塑机
16	1300	2015-6	1000	600	350	1300	SR19* \varnothing 8.5	1410*1260	2800	980*880	600~1300	东华注塑机
17	2850	2018-9	1370	1100	450	1880	SR25* \varnothing 10.5	2000*1800	3960	1400*1260	900~1880	东华注塑机
18	1800	2012-5	850	645	380	1500	SR19* \varnothing 8.5	1600*1400	3000	1100*980	700~1500	东华注塑机
19	1800	2013-12	850	645	380	1500	SR19* \varnothing 8.5	1600*1400	3000	1100*980	700~1500	东华注塑机



320T、450T、800T系列双色注塑机主要用于双材质两次注塑一次成型。此技术是我公司与东华公司共同开发。

其设备是双螺杆注塑成型机（T型），操作简单，节约能源，主要应用在汽车行业。

320T 450T 800T series twin-color injection molding machine is mainly used for twin-material two injection molding and one molding. This technology is jointly developed by our company and Donghua company.

Its equipment is twin-screw injection molding machine (model T).

万能实验机

universal testing machine

主要用于复合材料进行常规力学性能指标的测试。能够自动求取抗拉强度、剥离强度、撕裂强度等。



简支梁冲击试验机

Simply supported beam impact test machine

主要用于硬质塑料、增强尼龙、玻璃钢、陶瓷、铸石、电绝缘材料等非金属材料冲击韧性的测定。



熔体流动速率仪

Melt flow rate meter

主要测定各种高聚物在粘流状态时熔体流动速率，它既适用于熔融温度较高PC、PS、PP、等熔融温度较低的塑料测试。



橡胶硬度计

rubber hardness meter

A型适用于一般橡胶、合成橡胶、软橡胶、多元脂、皮革、蜡等。邵氏橡胶硬度计是测定硫化橡胶和塑料制品硬度的仪器





2010年



一汽-大众

NCS导流板

材料：PP+TPE

方式：边缘对接

NCS baffle

Material :PP+TPE

Mode: edge butt joint

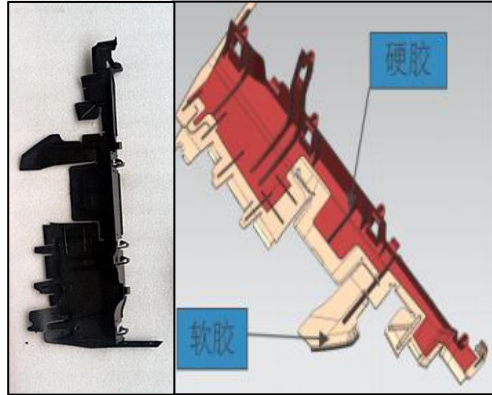

2015年



比速汽车

S25 A柱 (高光) 材料：PMMA +TPE 方式：边缘对接

S25 A column (highlight) material :PMMA +TPE mode: edge butt joint

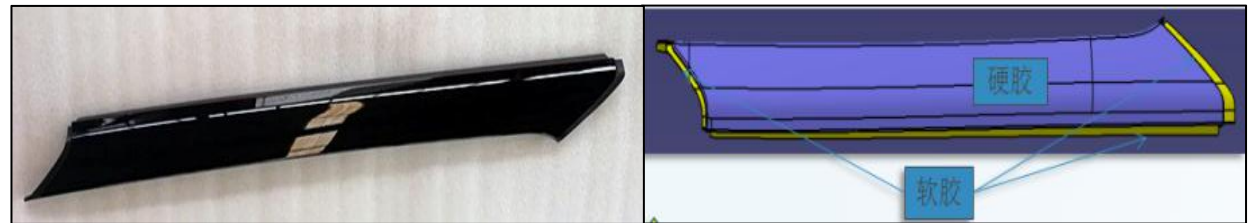

2014年



C20装饰条

材料：PP+TPV

方式：TPV完全包覆

PPC20 decorative strip

material :PP+TPV

mode :TPV

completely covers PP

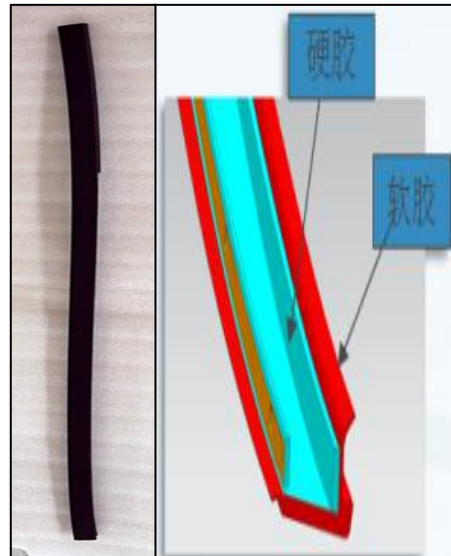

2016-2017年



K01门框装饰板 (高光)

材料：PMMA+ABS

方式：PMMA完全包覆ABS

K01 door frame decoration board (highlight)

material :PMMA+ABS

mode :PMMA completely covers ABS

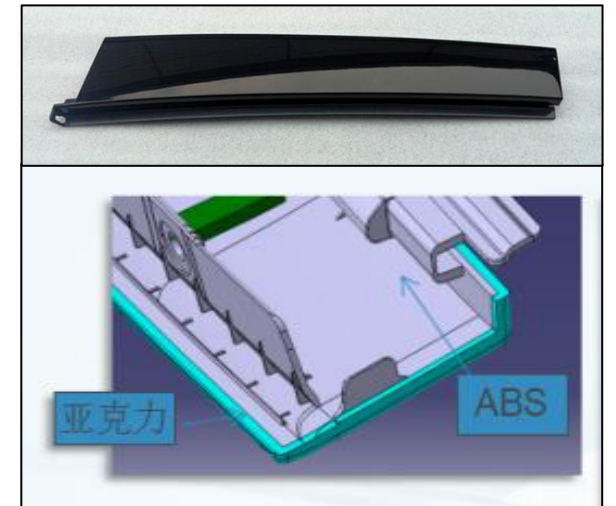

2016-2017年



国金汽车
SINOGOLD

K01门框密封条

材料：PP+TPV

方式：TPV完全包覆PP

K01 door frame sealing strip

material :PP+TPV

mode :TPV completely covers PP

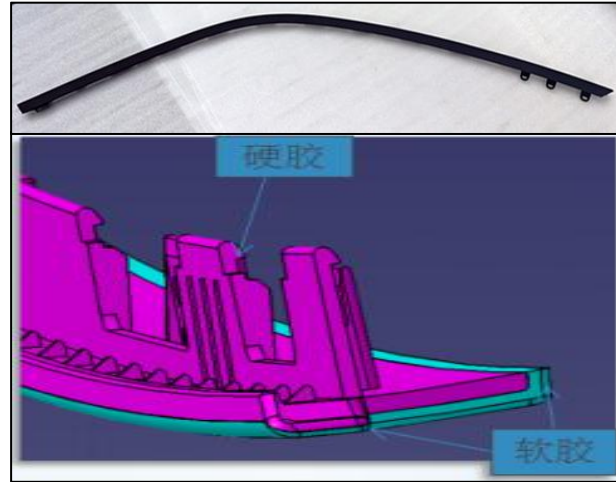

2016-2017年



国金汽车
SINOGOLD

K01充电口

材料：PA6+TPE

方式：边缘对接

K01 charging port

material :PA6+TPE

mode: edge docking

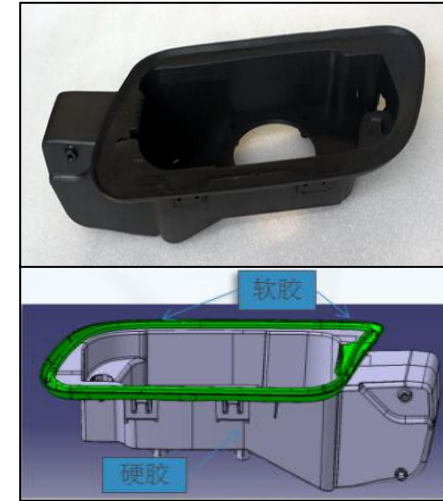

2016-2017年



国金汽车
SINOGOLD

K01前围通风盖板装置

材料：PP+TPE

方式：TPE完全包覆PP

K01 front ventilation cover

device material :PP+TPE

method :TPE completely covers

PP

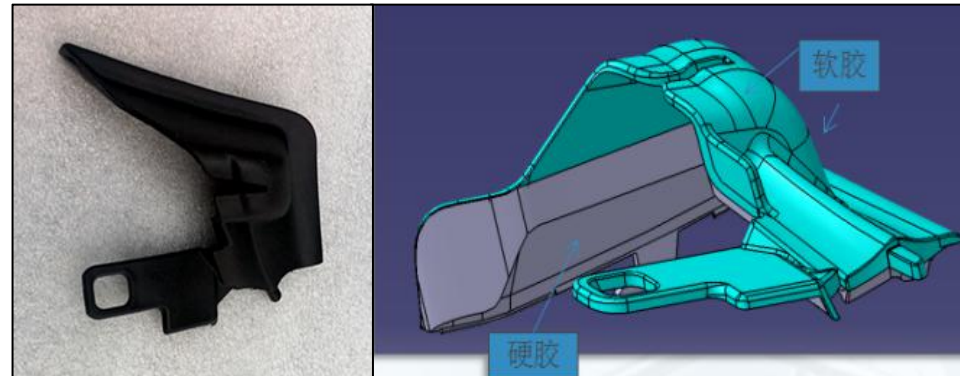



NF轮罩 NF wheel cover

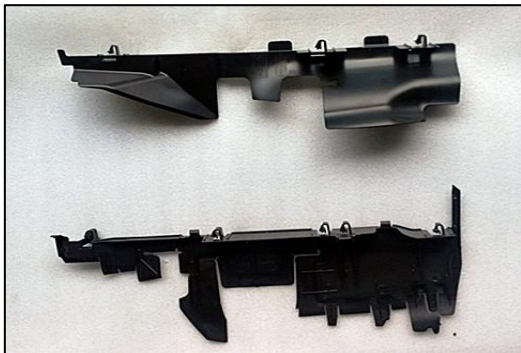

NCS、NF导流板
NF NCS guide plate



C20-S6顶盖装饰条
C20-s6 ceiling trim strip



前罩装饰件系列(S3L、S25、S7、H5)
Front cover decoration series (S3L S25 S7 H5)



S25 高光D柱
S25 highlight D pillar



S25 高光A柱
S25 highlights a-pillar

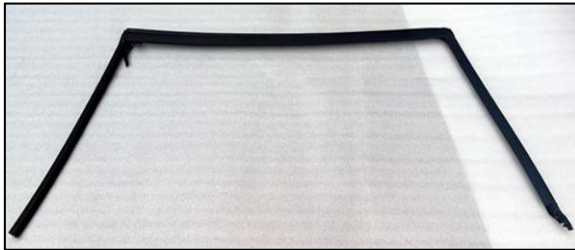

K01门框密封条总成
K01 door frame seal bar assembly

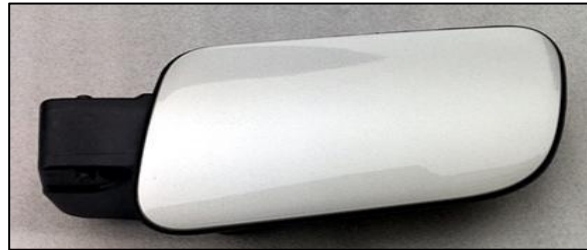

K01充电口总成
K01 charging port assembly



OSC 支撑总成
OSC support assembly



OSC 支架
OSC stents



K01门框装饰板总成(高光)
K01 door frame decorative plate assembly (highlight)



K01前后门水切
K01 front and back door water cut



SQ 支架
SQ stents



OSC-EV 底护板
OSC-EV Bottom Plate



P84行李箱侧装饰板总成

P84 Trunk Side Trim Panel Assembly



左行李箱侧装饰板总成 (低配)

Left Trunk Side Trim Panel Assembly (low fitting)



右行李箱侧装饰板总成 (低配)

Trim Panel Assembly on right side of suitcase (low fitting)



左行李箱侧装饰板总成 (高配)

Left Trunk Side Trim Panel Assembly (high fitting)



右行李箱侧装饰板总成 (高配)

Trim Panel Assembly on right suitcase side (high fitting)



P3011空调壳体总成

P3011 air conditioning housing assembly

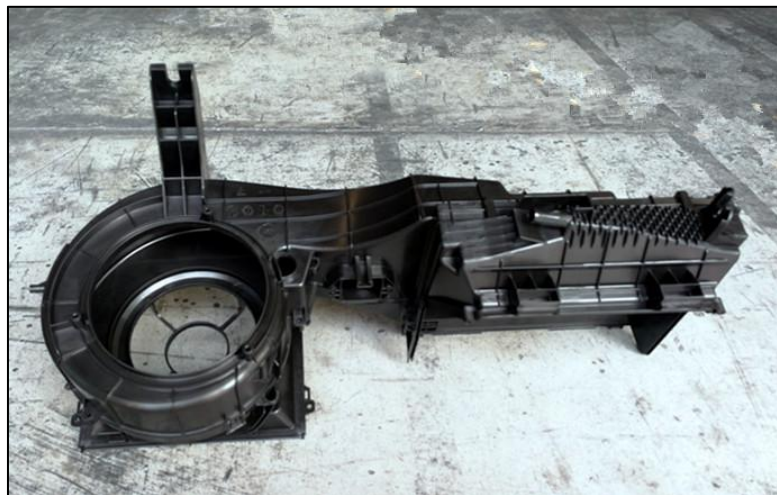

鼓蒸壳体 Steam drum shell

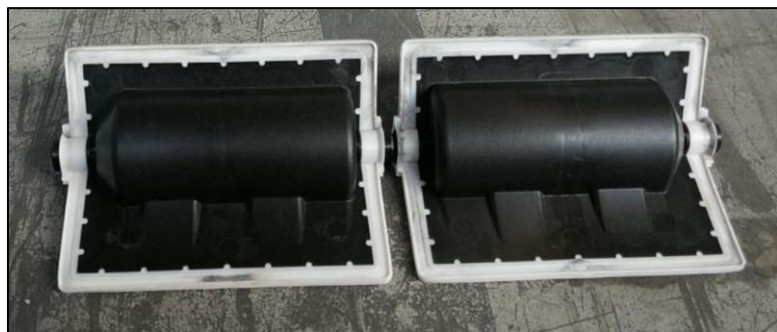

冷暖风门 Changes in temperature air door



空气调节器壳体
Air regulator housing



鼓风机壳体 Blower housing



吹面除霜风口 Blow face defrost tuyere



保险杠装饰板 Bumper trim plate



保险杠装饰条
Bumper trim



康福万家公司产品

Kangfu Wanjia Company Series Products



净化器C95总成
Purifier C95
assembly

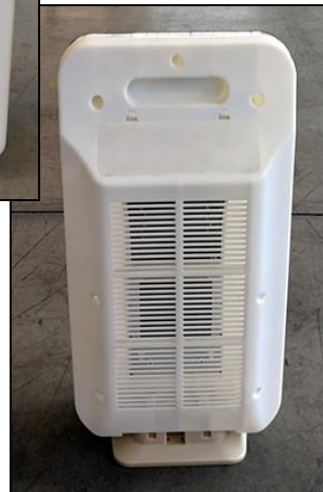

C30坐灸总成
C30 sitting moxibustion assembly



C128总成
C128 assembly

组装塑料托盘系列
assembles plastic tray series

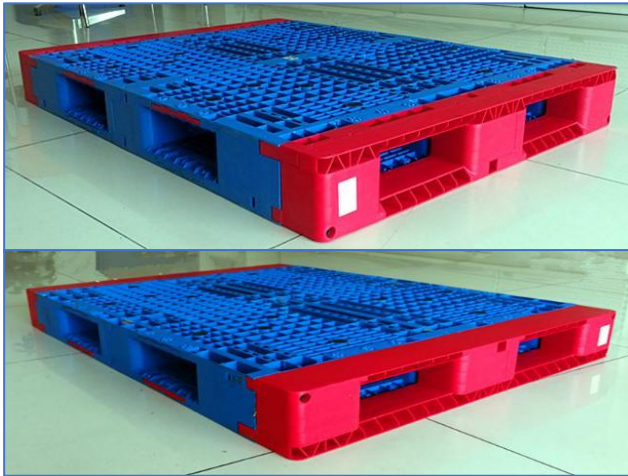

双面托盘
Double sided tray

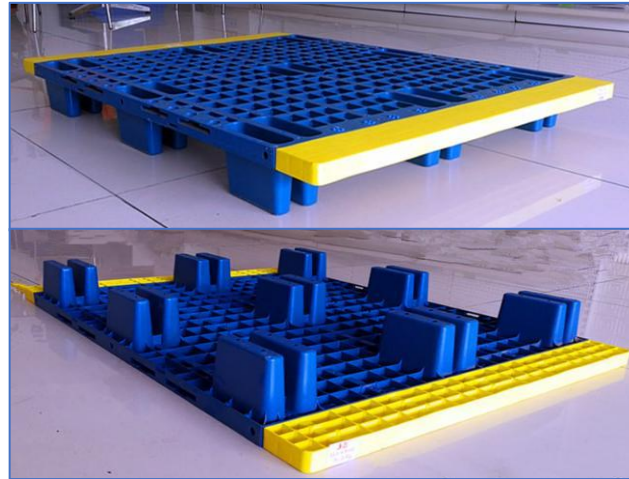

单面托盘
Single Tray

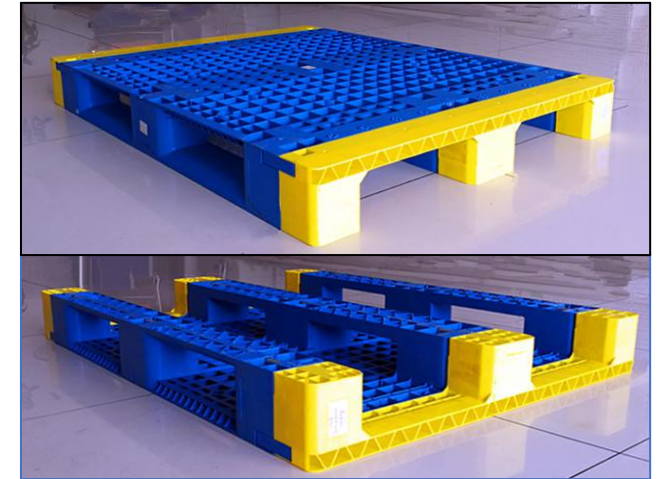

川字托盘
Sichuan Tray

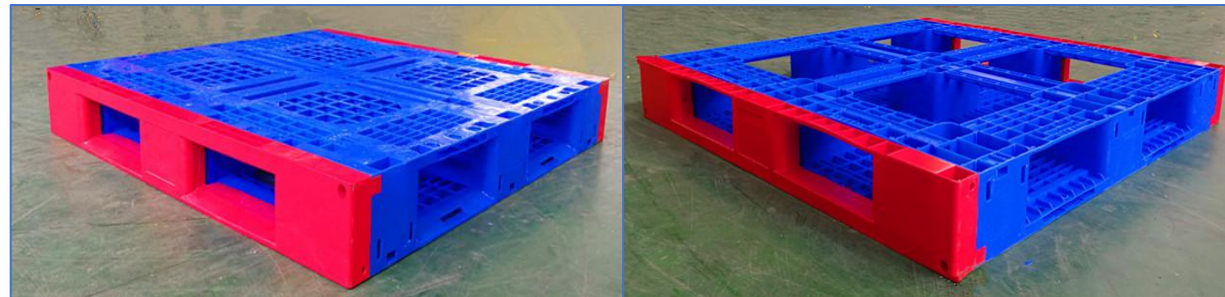

田字托盘
Tian word tray

塑料框系列产品
Series Products

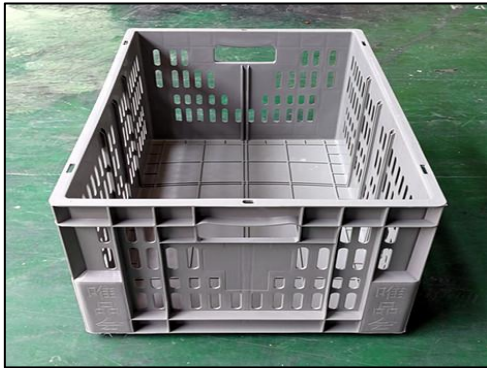

唯品会定制箱
The only products
will be custom boxes



周转框系列产品
Swing frame series products



牧草箱
Herbage box



普洛斯定制箱
Pullos custom
box



BDU电器盒总成
BDU electrical box assembly



电器盒上盖 Electrical box cover

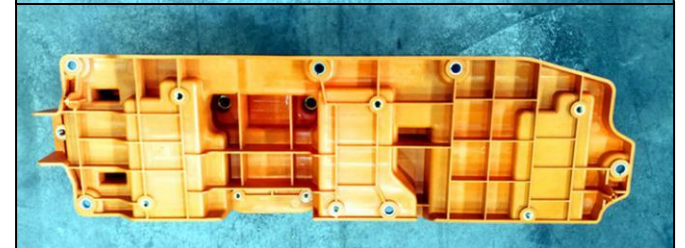
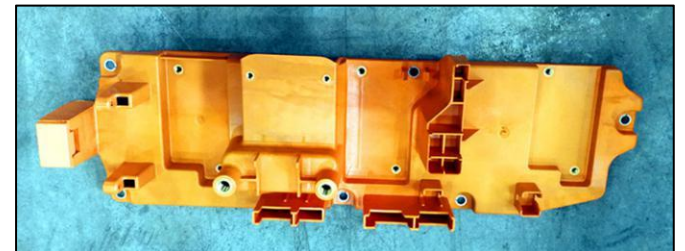

电器盒下盖 Electrical box cover



彩电显示器壳体系列

Rear cover series of color TV display



65V8



65P9



65C8



55P9

公司地址：成都市经济开发区（龙泉驿区）车城东二路401号

业务联系人：赖云

电话：13540259832

邮箱：laiyun524@sina.com

邮编：610100

传真：028-68615072

合作·共赢

合作才会成功

共赢才会精彩

